

PROBLEM – 12.

ANALYTICAL AND FINITE ELEMENT SOLUTION OF A PLATE WITH CENTRAL HOLE

Author: Dr. András Szekrényes

12. ANALYTICAL AND FINITE ELEMENT SOLUTION OF A PLATE WITH CENTRAL HOLE

Calculate the stress field in the in-plane loaded plate with central hole shown in Fig.12.1

- analytically by the help of the basic equations of elasticity,
- by finite element method using the code ANSYS,

moreover, compare the results obtained from the two different calculations! The material of the plate is linear elastic, homogeneous and isotropic.

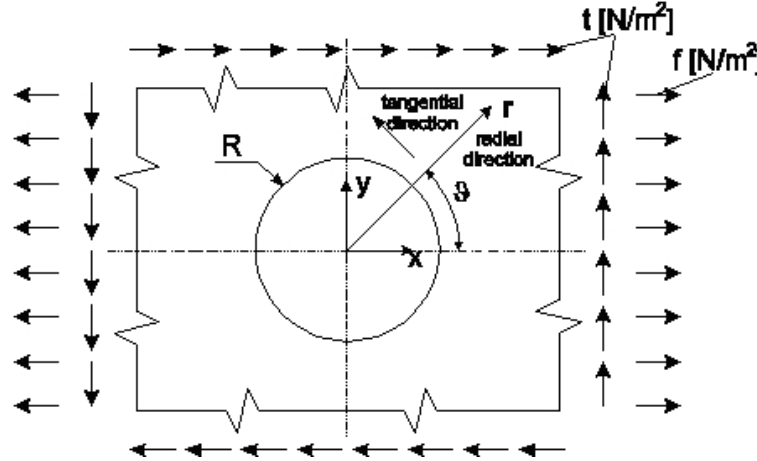

Fig.12.1. Plate with central hole subjected to normal load in direction x and tangential load along the boundaries.

12.1 Analytical solution

The governing equation of plane problems has already been derived in cylindrical coordinate system in section 11 (see Eq.(11.74)):

$$\nabla^4 \chi = \nabla^2 \nabla^2 \chi = \left(\frac{\partial^2}{\partial r^2} + \frac{1}{r} \frac{\partial}{\partial r} + \frac{1}{r^2} \frac{\partial^2}{\partial \vartheta^2} \right) \left(\frac{\partial^2}{\partial r^2} + \frac{1}{r} \frac{\partial}{\partial r} + \frac{1}{r^2} \frac{\partial^2}{\partial \vartheta^2} \right) \chi = 0, \quad (12.1)$$

which is a partial differential equation involving dynamic boundary conditions (formulated for the stress field). Accordingly, a boundary value problem should be solved. The stresses are expressed by the following equations (refer to section 11):

$$\sigma_r = \frac{1}{r} \frac{\partial \chi}{\partial r} + \frac{1}{r^2} \frac{\partial^2 \chi}{\partial \vartheta^2}, \quad \sigma_\vartheta = \frac{\partial^2 \chi}{\partial r^2}, \quad \tau_{r\vartheta} = -\frac{\partial}{\partial r} \left(\frac{1}{r} \frac{\partial \chi}{\partial \vartheta} \right). \quad (12.2)$$

The problem can be solved by the method of Fourier, i.e. it is assumed that the solution function is separable with respect to the variables [1]:

$$\chi(r, \vartheta) = \sum_{i=1}^{\infty} R_i(r) \Phi_i(\vartheta). \quad (12.3)$$

Taking it back into the governing equation given by Eq.(12.1) we obtain:

$$\frac{1}{r} \frac{d}{dr} \left\{ \left(r \frac{d}{dr} \right) \left[\frac{1}{r} \frac{d}{dr} \left(r \frac{dR}{dr} \right) \right] \right\} \Phi + \frac{1}{r} \frac{d}{dr} \left[r \frac{d}{dr} \left(\frac{1}{r^2} R \right) \right] \Phi'' + \frac{1}{r^3} \frac{d}{dr} \left(r \frac{dR}{dr} \right) \Phi'' + \frac{1}{r^4} R \Phi^{IV} = 0. \quad (12.4)$$

The solution in terms of variable r is searched in the form of a power function:

$$R(r) = r^n. \quad (12.5)$$

Taking it back into Eq.(12.4) the following is obtained:

$$n^2(n-2)^2\Phi + [(n-2)^2 + n^2]\Phi'' + \Phi^{IV} = 0. \quad (12.6)$$

a. Let us assume that:

$$\Phi'' = \Phi^{IV}, \quad (12.7)$$

which is possible only if Φ is the sum of constant and linear terms:

$$\Phi(\vartheta) = C_1 + C_2\vartheta, \quad (12.8)$$

where C_1 and C_2 are constants. As a consequence Eq.(12.6) reduces to:

$$n^2(n-2)^2\Phi = 0, \quad (12.9)$$

which is satisfied if $n = 0$ or 2 , however each root is a double root due to the second power.

The differential equation to be solved based on Eq.(12.4) is:

$$\frac{1}{r} \frac{d}{dr} \left\{ \left(r \frac{d}{dr} \right) \left[\frac{1}{r} \frac{d}{dr} \left(r \frac{dR}{dr} \right) \right] \right\} = 0. \quad (12.10)$$

We integrate the equation with respect to r :

$$r \frac{d}{dr} \left[\frac{1}{r} \frac{d}{dr} \left(r \frac{dR}{dr} \right) \right] = c_1. \quad (12.11)$$

As a next step we divide the equation by r and integrate again with respect to r :

$$\left[\frac{1}{r} \frac{d}{dr} \left(r \frac{dR}{dr} \right) \right] = c_1 \ln r + c_2. \quad (12.12)$$

Now we multiply the equation by r and integrate it third time:

$$r \frac{dR}{dr} = c_1 \int r \ln r dr + c_2 \frac{r^2}{2} + c_3. \quad (12.13)$$

The partial integration of the first term on the right hand side yields:

$$r \frac{dR}{dr} = c_1 \frac{1}{2} \left(r^2 \ln r - \frac{r^2}{2} \right) + c_2 \frac{r^2}{2} + c_3. \quad (12.14)$$

We divide the result by r and integrate it even fourth time:

$$R(r) = Ar^2 + B \ln r + Cr^2 \ln r + D, \quad (12.15)$$

where A , B , C and D are constants. Summarizing the results of case a. the elements of the basic function system are:

$$\{r^2, \ln r, r^2 \ln r, 1\} \text{ and } \vartheta \{r^2, \ln r, r^2 \ln r, 1\}. \quad (12.16)$$

These function, however are not periodic functions. It may be assumed that the solution function is periodic, i.e. it contains trigonometric functions.

b. Because of the even derivatives we assume that the solution is the combination of trigonometric functions:

$$\Phi(\vartheta) = \begin{Bmatrix} \cos(i\vartheta) \\ \sin(i\vartheta) \end{Bmatrix}, \quad (12.17)$$

accordingly:

$$\Phi''(\vartheta) = -i^2 \begin{Bmatrix} \cos(i\vartheta) \\ \sin(i\vartheta) \end{Bmatrix}, \quad \Phi^{IV}(\vartheta) = i^4 \begin{Bmatrix} \cos(i\vartheta) \\ \sin(i\vartheta) \end{Bmatrix}. \quad (12.18)$$

From Eq.(12.6) we obtain:

$$n^2(n-2)^2 + i^2[(n-2)^2 + n^2] + i^4 = 0. \quad (12.19)$$

Let us investigate the possible values of parameter i ! Eq.(12.19) is a second order equation for i^2 of which solutions are:

$$i^2 = \frac{1}{2} \left\{ [(n-2)^2 + n^2] \pm [(n-2)^2 - n^2] \right\}, \quad (12.20)$$

viz.:

$$i^2 = \left\{ \begin{array}{c} n^2 \\ (n-2)^2 \end{array} \right\}. \quad (12.21)$$

If $n = 1$ then for both cases the result is $i^2 = 1$, i.e. for $n = 1$ we have double roots. The solution in terms of r is $R(r) = r$, and the elements of the basic function system become:

$$\{r \cos \vartheta, r \sin \vartheta, r \vartheta \cos \vartheta, r \vartheta \sin \vartheta\}. \quad (12.22)$$

From Eq.(12.21) we express the value of n in terms of i :

$$n = \left\{ \begin{array}{c} \pm i \\ \pm i + 2 \end{array} \right\}. \quad (12.23)$$

Let us investigate that in which cases we have double roots! If $i = 1$ then $n = 1, -1, 3, 1$, accordingly there exists one double root, and so the elements of the basic function system utilizing $R(r) = r^n$ are:

$$i = 1: \left\{ r, \frac{1}{r}, r^3, r \ln r \right\}, \quad (12.24)$$

where the last term is the fourth independent element due to the double root. If $i = 2$ then $n = 2, -2, 4, 0$, accordingly there is not any double root and the elements of the basic function system are:

$$i = 2: \left\{ r^2, \frac{1}{r^2}, r^4, 1 \right\}. \quad (12.25)$$

It can be seen based on Eq.(12.23) that if $i > 1$ then there is no double root, i.e. the solution can be presented in reduced form if $i > 1$. Let us summarize the solution function [1]!

$$\begin{aligned} \chi(r, \vartheta) = & a_{01} + a_{02} \ln r + a_{03} r^2 + a_{04} r^2 \ln r + \\ & + (a_{11} r + a_{12} \frac{1}{r} + a_{13} r^3 + a_{14} r \ln r) \cos \vartheta + \\ & + (b_{11} r + b_{12} \frac{1}{r} + b_{13} r^3 + b_{14} r \ln r) \sin \vartheta + \\ & + \sum_{i=2}^{\infty} (a_{i1} r^i + a_{i2} r^{-i} + a_{i3} r^{2+i} + a_{i4} r^{2-i}) \cos i \vartheta + \\ & + \sum_{i=2}^{\infty} (b_{i1} r^i + b_{i2} r^{-i} + b_{i3} r^{2+i} + b_{i4} r^{2-i}) \sin i \vartheta + \\ & + (c_1 + c_2 \ln r + c_3 r^2 + c_4 r^2 \ln r) \vartheta + \\ & + c_5 r \vartheta \cos \vartheta + c_6 r \vartheta \sin \vartheta + \\ & + \chi_p(r, \vartheta), \end{aligned} \quad (12.26)$$

where the 1st, 6th and 7th rows contain the non-periodic solutions, rows 2nd-5th contain the periodic solutions when $i = 1$ and $i = 2.. \infty$. In the 7th row we included the missing terms due to the double roots for $n = 1$, finally the last term is the function of particular solution. Eventually, Eq.(12.26) can be applied to any plane problem on condition that we use cy-

lindrical coordinate system. Let us get back now to the original problem! The stress tensor in a point sufficiently far from the hole is:

$$\underline{\underline{\sigma}}_{x,y,z} = \begin{bmatrix} f & t & 0 \\ t & 0 & 0 \\ 0 & 0 & 0 \end{bmatrix}. \quad (12.27)$$

We transform the stresses into the r - ϑ cylindrical coordinate system. The unit basis vectors of the cylindrical coordinate system are:

$$\underline{e}_r = \cos \vartheta \underline{i} + \sin \vartheta \underline{j} \quad \text{and} \quad \underline{e}_\vartheta = -\sin \vartheta \underline{i} + \cos \vartheta \underline{j}. \quad (12.28)$$

The radial stress based on the stress transformation expression is:

$$\sigma_r^\infty = \underline{e}_r^T \underline{\underline{\sigma}}_{x,y,z} \underline{e}_r = \begin{bmatrix} c & s & 0 \end{bmatrix} \begin{bmatrix} f & t & 0 \\ t & 0 & 0 \\ 0 & 0 & 0 \end{bmatrix} \begin{bmatrix} c \\ s \\ 0 \end{bmatrix} = fc^2 + 2cst, \quad (12.29)$$

where $c = \cos \vartheta$ and $s = \sin \vartheta$. Utilizing that $\cos^2 \vartheta = 1/2 \cdot (\cos(2\vartheta) + 1)$ and $\sin^2 \vartheta = 2 \cdot \cos \vartheta \sin \vartheta$ we obtain:

$$\sigma_r^\infty = \frac{1}{2} f (\cos 2\vartheta + 1) + t \sin 2\vartheta. \quad (12.30)$$

The tangential stress and the shear stress are calculated in a similar fashion:

$$\sigma_\vartheta^\infty = \underline{e}_\vartheta^T \underline{\underline{\sigma}}_{x,y,z} \underline{e}_\vartheta = \frac{1}{2} f (1 - \cos 2\vartheta) - t \sin 2\vartheta, \quad (12.31)$$

$$\tau_{r\vartheta}^\infty = \underline{e}_r^T \underline{\underline{\sigma}}_{x,y,z} \underline{e}_\vartheta = -\frac{1}{2} f \sin 2\vartheta + t \cos 2\vartheta.$$

Comparing Eqs.(12.30)-(12.31) to the solution of Airy's stress function in Eq.(12.26) the following terms remain:

$$\begin{aligned} \chi(r, \vartheta) = & a_{01} + a_{02} \ln r + a_{03} r^2 + a_{04} r^2 \ln r + \\ & + (a_{21} r^2 + a_{22} r^{-2} + a_{23} r^4 + a_{24}) \cos 2\vartheta + \\ & + (b_{21} r^2 + b_{22} r^{-2} + b_{23} r^4 + b_{24}) \sin 2\vartheta, \end{aligned} \quad (12.32)$$

which contains all in all twelve constants. Let us investigate the terms in the 1st row! The stress components become independent of ϑ , from Eq.(12.2) we obtain:

$$\sigma_r = \frac{1}{r} \frac{\partial \chi}{\partial r} = a_{02} \frac{1}{r^2} + 2a_{03} + a_{04} (2 \ln r + 1), \quad (12.33)$$

$$\sigma_r = \frac{\partial^2 \chi}{\partial r^2} = -a_{02} \frac{1}{r^2} + 2a_{03} + a_{04} (2 \ln r + 3).$$

$$\tau_{r\vartheta} = 0.$$

The strain components are calculated using Hooke's law for plane stress state based on Eq.(11.68):

$$E\varepsilon_r = (\sigma_r - \nu\sigma_\vartheta) = a_{02} \frac{1}{r^2} (1 + \nu) + 2a_{03} (1 - \nu) + 2a_{04} (1 - \nu) \ln r + a_{04} (1 - 3\nu), \quad (12.34)$$

$$E\varepsilon_\vartheta = (\sigma_\vartheta - \nu\sigma_r) = -a_{02} \frac{1}{r^2} (1 + \nu) + 2a_{03} (1 - \nu) + 2a_{04} (1 - \nu) \ln r + a_{04} (3 - \nu).$$

Moreover, the shear strain is zero. The relationship between the displacement field and the strain components is given by Eq.(11.66):

$$\varepsilon_r = \frac{\partial u}{\partial r}, \quad \varepsilon_{\vartheta} = \frac{u}{r}. \quad (12.35)$$

We express the radial displacement, u from both equations:

$$\int E\varepsilon_r dr = \int E \frac{\partial u}{\partial r} dr = Eu = -a_{02} \frac{1}{r}(1+\nu) + 2a_{03}(1-\nu)r + 2a_{04}(1-\nu)r \ln r - a_{04}(1+\nu)r, \quad (12.36)$$

$$E\varepsilon_{\vartheta} r = Eu = -a_{02} \frac{1}{r}(1+\nu) + 2a_{03}(1-\nu)r + 2a_{04}(1-\nu)r \ln r + a_{04}(3-\nu)r,$$

Comparing the results it is elaborated that the term after a_{04} leads to an incompatible displacement field. This contradiction can be resolved only if:

$$a_{04} = 0. \quad (12.37)$$

In the case of the other terms there are no compatibility problems. Next, we calculate the stresses considering all of the terms in Eq.(12.32):

$$\begin{aligned} \sigma_r &= \frac{1}{r} \frac{\partial \chi}{\partial r} + \frac{1}{r^2} \frac{\partial^2 \chi}{\partial \vartheta^2} = a_{02} \frac{1}{r^2} + 2a_{03} + \\ &- (2a_{21}r^2 + 6a_{22}r^{-4} + 4a_{24}r^{-2}) \cos 2\vartheta - (2b_{21} + 6b_{22}r^{-4} + 4b_{24}r^{-2}) \sin 2\vartheta, \end{aligned} \quad (12.38)$$

$$\sigma_{\vartheta} = \frac{\partial^2 \chi}{\partial r^2} = -a_{02} \frac{1}{r^2} + 2a_{03} + (2a_{21}r^2 + 6a_{22}r^{-4}) \cos 2\vartheta + (2b_{21} + 6b_{22}r^{-4}) \sin 2\vartheta,$$

$$\tau_{r\vartheta} = -\frac{\partial}{\partial r} \left(\frac{1}{r} \frac{\partial \chi}{\partial \vartheta} \right) = 2(a_{21} - 3a_{22}r^{-4} - a_{24}r^{-2}) \sin 2\vartheta - (2b_{21} - 3b_{22}r^{-4} - b_{24}r^{-2}) \cos 2\vartheta,$$

where we can notice that the terms a_{23} and b_{23} vanish, which can be explained mathematically by the fact that for $r = \infty$ finite stresses are required. There are still eight unknown constants in the stress formulae. These eight constants can be obtained based on the boundary conditions of the problem. We incorporate Eqs.(12.30) and (12.31), which give the stress state at any point, which is located at an infinitely far r distance from the hole:

$$\sigma_r^{\infty} = \sigma_r(\infty, \vartheta) \Rightarrow \frac{1}{2}f + \frac{1}{2}f \cos 2\vartheta + t \sin 2\vartheta = 2a_{03} - 2a_{21} \cos 2\vartheta - 2b_{21} \sin 2\vartheta, \quad (12.39)$$

$$\sigma_{\vartheta}^{\infty} = \sigma_{\vartheta}(\infty, \vartheta) \Rightarrow \frac{1}{2}f - \frac{1}{2}f \cos 2\vartheta - t \sin 2\vartheta = 2a_{03} + 2a_{21} \cos 2\vartheta + 2b_{21} \sin 2\vartheta,$$

and this yields:

$$a_{03} = \frac{1}{4}f, \quad a_{21} = -\frac{1}{4}f, \quad b_{21} = -\frac{1}{2}t. \quad (12.40)$$

Further five constants can be calculated based on the dynamic boundary conditions. If $r = R$ then the hole is free to load independently of the angle coordinate ϑ , consequently:

$$\sigma_r(R, \vartheta) = 0 \Rightarrow \left\{ \begin{array}{l} a_{02} \frac{1}{R^2} + \frac{1}{2}f = 0 \\ -\frac{f}{2} + 6a_{22} \frac{1}{R^4} + 4a_{24} \frac{1}{R^2} = 0 \\ -t + 6b_{22} \frac{1}{R^4} + 4b_{24} \frac{1}{R^2} = 0 \end{array} \right\}, \quad (12.41)$$

$$\tau_{r\vartheta}(R, \vartheta) = 0 \Rightarrow \left\{ \begin{array}{l} -\frac{f}{2} - 3a_{22} \frac{1}{R^4} - a_{24} \frac{1}{R^2} = 0 \\ -\frac{t}{2} - 3b_{22} \frac{1}{R^4} - b_{24} \frac{1}{R^2} = 0 \end{array} \right\}.$$

The solutions of the system of equations are:

$$a_{02} = -f \frac{R^2}{2}, \quad a_{22} = -f \frac{R^4}{4}, \quad a_{24} = f \frac{R^2}{2}, \quad b_{22} = -t \frac{R^4}{2}, \quad b_{24} = tR^2. \quad (12.42)$$

Taking the constants back into the stress formulae we obtain:

$$\sigma_r(r, \vartheta) = \frac{f}{2} \left(1 - \frac{R^2}{r^2}\right) + \frac{f}{2} \left(1 - 4 \frac{R^2}{r^2} + 3 \frac{R^4}{r^4}\right) \cos 2\vartheta + t \left(1 - 4 \frac{R^2}{r^2} + 3 \frac{R^4}{r^4}\right) \sin 2\vartheta, \quad (12.43)$$

$$\sigma_\vartheta(r, \vartheta) = \frac{f}{2} \left(1 + \frac{R^2}{r^2}\right) - \frac{f}{2} \left(1 + 3 \frac{R^4}{r^4}\right) \cos 2\vartheta - t \left(1 + 3 \frac{R^4}{r^4}\right) \sin 2\vartheta,$$

$$\tau_{r\vartheta}(r, \vartheta) = -\frac{f}{2} \left(1 + 2 \frac{R^2}{r^2} - 3 \frac{R^4}{r^4}\right) \sin 2\vartheta + t \left(1 + 2 \frac{R^2}{r^2} - 3 \frac{R^4}{r^4}\right) \cos 2\vartheta.$$

To plot the functions of stress field let us perform the function analysis of the solution!

I. $\vartheta = 90^\circ$, this leads to:

$$\sigma_\vartheta(R) = \frac{f}{2} (1+1) + \frac{f}{2} (1+3) = 3f, \quad (12.44)$$

$$\sigma_\vartheta(2R) = \frac{f}{2} (1+1/4) + \frac{f}{2} (1+3/16) = 39/32 f = 1,22 f,$$

$$\sigma_\vartheta(4R) = \frac{f}{2} (1+1/16) + \frac{f}{2} (1+3/256) = 531/516 f = 1,037 f,$$

$$\sigma_r(R) = 0 \text{ - dynamic boundary condition.}$$

II. $\vartheta = 0^\circ$, $\cos(2\vartheta) = 1$, $\sin(2\vartheta) = 0$, i.e:

$$\sigma_r(r) = \frac{f}{2} \left(1 - \frac{R^2}{r^2}\right) + \frac{f}{2} \left(1 - 4 \frac{R^2}{r^2} + 3 \frac{R^4}{r^4}\right), \quad (12.45)$$

moreover, if $r = R$ then $\sigma_r(r) = 0$, which is also a dynamic boundary condition. Let us search the extreme value of $\sigma_r(r)$:

$$\left. \frac{d\sigma_r(r)}{dr} \right|_{\vartheta=0^\circ} = 2 \frac{f}{2} \frac{R^2}{r^3} + \frac{f}{2} (4 \cdot 2 \frac{R^2}{r^3} + 3(-4) \frac{R^4}{r^5}) = 0, \quad (12.46)$$

from which we obtain $r = \sqrt{1,2}R$. Taking it back and calculating the extreme value we have:

$$\sigma_r(\sqrt{1,2}R) = \frac{f}{2} \left(1 - \frac{1}{1,2}\right) + \frac{f}{2} \left(1 - 4 \frac{1}{1,2} + 3 \frac{1}{1,2^2}\right) = -0,0417 f. \quad (12.47)$$

Let us calculate the root of the function:

$$1 - \frac{R^2}{r^2} + 1 - 4 \frac{R^2}{r^2} + 3 \frac{R^4}{r^4} = 0, \quad (12.48)$$

which yields $r = \sqrt{1,5}R$. Finally, if $r \Rightarrow \infty$ then $\sigma_r = f$.

III. Along the circumference of the hole there is a uniaxial stress state, which is justified by the followings:

$\sigma_r(R, \vartheta) = 0$ and $\tau_{r\vartheta}(R, \vartheta) = 0$ due to the dynamic boundary conditions, furthermore:

$$\sigma_{\vartheta}(R, \vartheta) = \frac{f}{2} + \frac{f}{2}(1+3)\cos 2\vartheta = f - 2f \cos 2\vartheta, \quad (12.49)$$

and based on $1 - 2\cos 2\vartheta = 0$ the root of this function is calculated from: $\cos 2\vartheta = 1/2 \Rightarrow \vartheta = 30^\circ$.

IV. If $f = 0$ and there is only tangential load t , then at $r = R$ we have $\sigma_r(R, \vartheta) = \tau_{r\vartheta}(R, \vartheta) = 0$ and $\sigma_{\vartheta}(R, \vartheta) = -4t \sin 2\vartheta$.

The results are presented in Figs.12.2 and 12.3. We note that the problem of plate with central hole can be solved also by complex variable functions, see e.g. [2,3].

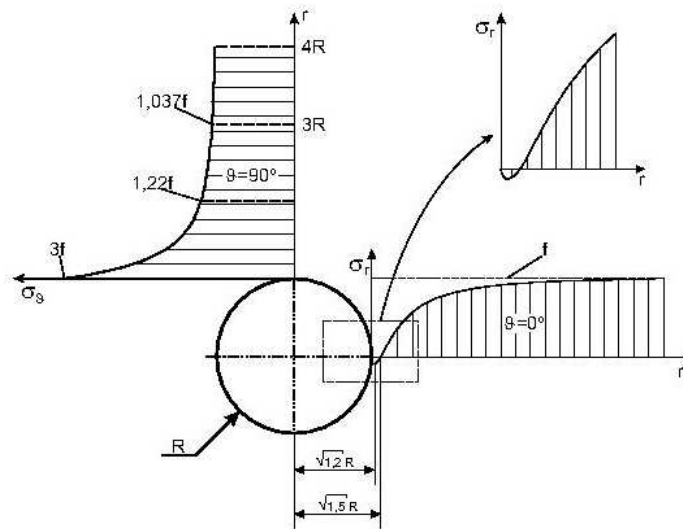

Fig.12.2. Tangential stresses if $\vartheta = 90^\circ$ and radial stresses if $\vartheta = 0^\circ$ in a plate with central hole.

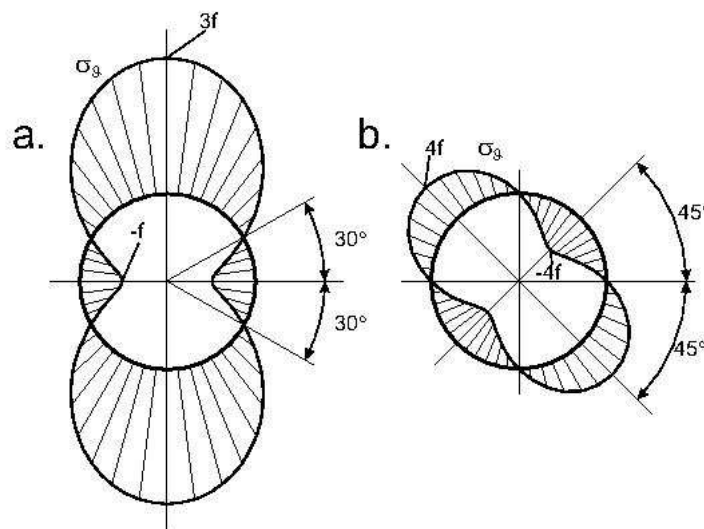

Fig.12.3. Tangential stresses in a plate with circular hole subjected to uniaxial tension in direction x (a) and tangential load along the boundaries (b).

12.2 Finite element solution

Solve the problem of the plate with central hole shown in Fig.12.4 by the finite element method! Prepare the finite element model of the plate depicted in the figure; calculate the nodal displacements and stresses! Plot the distribution of normal and shear stresses along the symmetry lines!

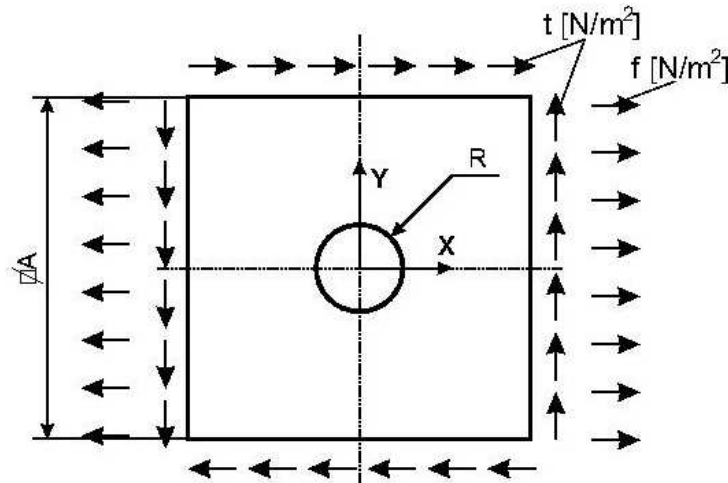

Fig.12.4. Finite dimension plate with central hole subjected to uniaxial tension and tangential load.

Given:

$A = 80 \text{ mm}$, $R = 8 \text{ mm}$, $f = 1 \text{ MPa}$, $t = 1 \text{ MPa}$, $E = 200 \text{ GPa}$, $\nu = 0,3$, $\nu = 1 \text{ mm}$

The finite element solution is presented by using the code ANSYS 12. The actual commands are available in the left hand side and upper vertical menus [4]. The distances are defined in [mm], the force is given in [N].

Printing the problem title on the screen

File menu / Change Title / Title: "Modeling of a plate with hole under plane stress state"
- refresh the screen by the mouse roller

Analysis type definition

PREFERENCES – STRUCTURAL

Element type definition – 4 node isoparametric plane element (PLANE42)

PREPROCESSOR / ELEMENT TYPES / ADD/EDIT/DELETE /ADD / SOLID / QUAD
4NODE 42 / OK /

PREPROCESSOR / OPTIONS / ELEMENT BEHAVIOR K3 – PLANE STRS W/THK /
OK / CLOSE

PREPROCESSOR / REAL CONSTANTS / ADD/EDIT/DELETE / ADD / OK / THK=1 /
OK / CLOSE – definition of the thickness

Material properties definition

PREPROCESSOR / MATERIAL PROPS / MATERIAL MODELS / STRUCTURAL /
LINEAR / ELASTIC / ISOTROPIC / EX = 200e3, PRXY = 0.3 / OK

Exit: Material menu / Exit

Geometry preparation

PREPROCESSOR / MODELING / CREATE / AREAS / RECTANGLES / BY 2 CORNERS / WPX = 0, WPY = 0, WIDTH = 20, HEIGHT = 20

- definition of the coordinates in the opening window

Click the 9th icon on the right entitled „Fit View”, it fits the screen to the actual object size.

PREPROCESSOR / MODELING / CREATE / AREAS / RECTANGLES / BY 2 CORNERS / WPX = 0, WPY = 0, WIDTH = 80, HEIGHT = 80 / APPLY

Creation of a further square

PREPROCESSOR / MODELING / CREATE / AREAS / RECTANGLES / BY 2 CORNERS / WPX = 20, WPY = 20, WIDTH = 60, HEIGHT = 60 / OK

Elimination of the overlapping areas

PREPROCESSOR / MODELING / OPERATE / BOOLEANS / OVERLAP / AREAS / PICK ALL

Creation of the hole

PREPROCESSOR / MODELING / CREATE / AREAS / CIRCLE / SOLID CIRCLE / WPX = 0, WPY = 0, RADIUS = 8 / OK

Subtraction of the hole from the smaller square

PREPROCESSOR / MODELING / OPERATE / BOOLEANS / SUBTRACT / AREAS
- selection of the smaller square by the mouse / OK
- selection of the circle by the mouse / OK

Bisection of the quarter arc of the hole

PREPROCESSOR / MODELING / OPERATE / BOOLEANS / DIVIDE / LINE
W/OPTIONS / OK /
- selection of the arc / OK

Connection of the quarter arc midpoint with the corner of the smaller square by a straight line

PREPROCESSOR / MODELING / CREATE / LINES / LINES / STRAIGHT LINE –
- selection of the points by the mouse / OK

Division of the smaller area by the line with inclination of 45°

PREPROCESSOR / MODELING / OPERATE / BOOLEANS / DIVIDE / AREA BY
LINE
- selection of the smallest area / OK
- selection of the line with inclination angle of 45° / OK

Fig.12.5 shows the process of creating the areas.

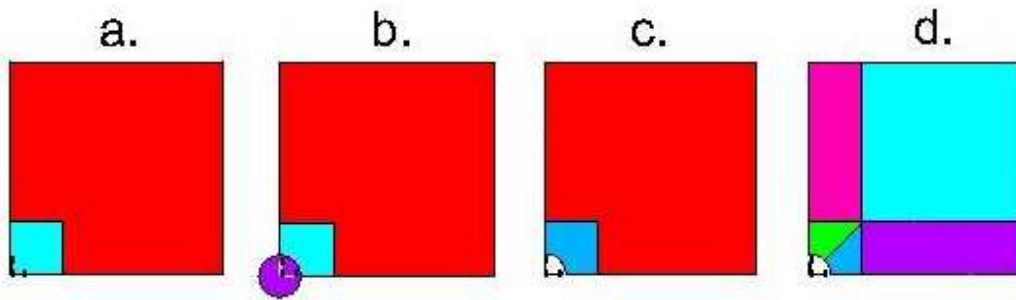

Fig.12.5. Preparation of the geometrical model of a plate with central hole.

Reflection of the model with respect to axis x

PREPROCESSOR / MODELING / REFLECT / AREAS / PICK ALL / X-Z PLANE Y / OK

Glue the areas to each other

PREPROCESSOR / MODELING / OPERATE / BOOLEANS / GLUE / AREAS / PICK ALL

Meshing

Element number definition along the lines based on Fig.12.6

PREPROCESSOR / MESHING / SIZE CNTRLS / MANUALSIZE / LINES / PICKED LINES / PICK / NO. OF ELEMENT DIVISIONS = typing in the proper number, repetition of the command

PREPROCESSOR / MESHING / MESH / AREAS / MAPPED / 3 OR 4 SIDED / PICK ALL

Plot menu / Multi-Plots – display the elements and nodes

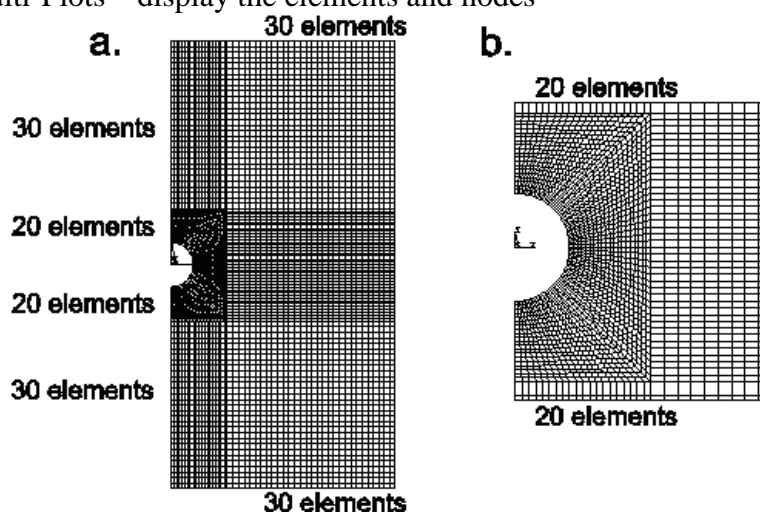

Fig.12.6. Details of the finite element model of the plate with central hole.

Reflection of the model with respect to axis y

PREPROCESSOR / MODELING / REFLECT / AREAS / PICK ALL / Y-Z PLANE X / OK

Glue the areas to each other

PREPROCESSOR / MODELING / OPERATE / BOOLEANS / GLUE / AREAS / PICK ALL

Elimination of the overlapping nodes along the vertical symmetry line

PREPROCESSOR / NUMBERING CTRLS / MERGE ITEMS / TOLER Range of coincidence = 0.05 / OK

Loading definition, load cases

Load case 1: $f = 1$ MPa distributed load in direction x

Kinematic constraints

PREPROCESSOR / LOADS / DEFINE LOADS / APPLY / STRUCTURAL / DISPLACEMENT / ON NODES

- selection of the lowest point on the vertical symmetry line / OK / UX, UY / APPLY

- selection of the highest point on the vertical symmetry line / OK / UX / OK

Definition of $f = 1$ MPa

PREPROCESSOR / LOADS / DEFINE LOADS / APPLY / STRUCTURAL / PRESSURE / ON LINES /

- selection of the lines with coordinate $x = 40$ and -40 mm by the mouse, intensity, VALUE Load PRES Value = -1

Read the load case as load step 1 (LS1)

PREPROCESSOR / LOADS / LOAD STEP OPTS / WRITE LS FILES / LSNUM = 1

Deletion of the load and kinematic constraints

PREPROCESSOR / LOADS / DEFINE LOADS / DELETE / STRUCTURAL / PRESSURE / ON LINES / PICK ALL

PREPROCESSOR / LOADS / DEFINE LOADS / DELETE / STRUCTURAL / DISPLACEMENT / ON NODES / PICK ALL / ALL DOF / OK

Load case 2: $t = 1$ MPa tangentially distributed load

PREPROCESSOR / LOADS / DEFINE LOADS / APPLY / STRUCTURAL / PRESSURE / ON ELEMENTS

- activation of the „box”, selection of elements on the right side on the upper longer horizontal boundary by the box / OK

LKEY = 4, VALUE LOAD PRES VALUE = 1 / APPLY

- activation of the „box”, selection of elements on the right side on the upper smaller horizontal boundary by the box / OK

LKEY = 1, VALUE LOAD PRES VALUE = 1 / APPLY

- activation of the „box”, selection of elements on the right side on the lower smaller horizontal boundary by the box / OK

LKEY = 3, VALUE LOAD PRES VALUE = 1 / APPLY

- activation of the „box”, selection of elements on the right side on the lower longer horizontal boundary by the box / OK

LKEY = 3, VALUE LOAD PRES VALUE = 1 / APPLY

Along the other boundaries the load should be defined according to Fig.12.7a, where we gave the values of LKEY for all of the boundary lines. The load is equal to unity on each boundary line.

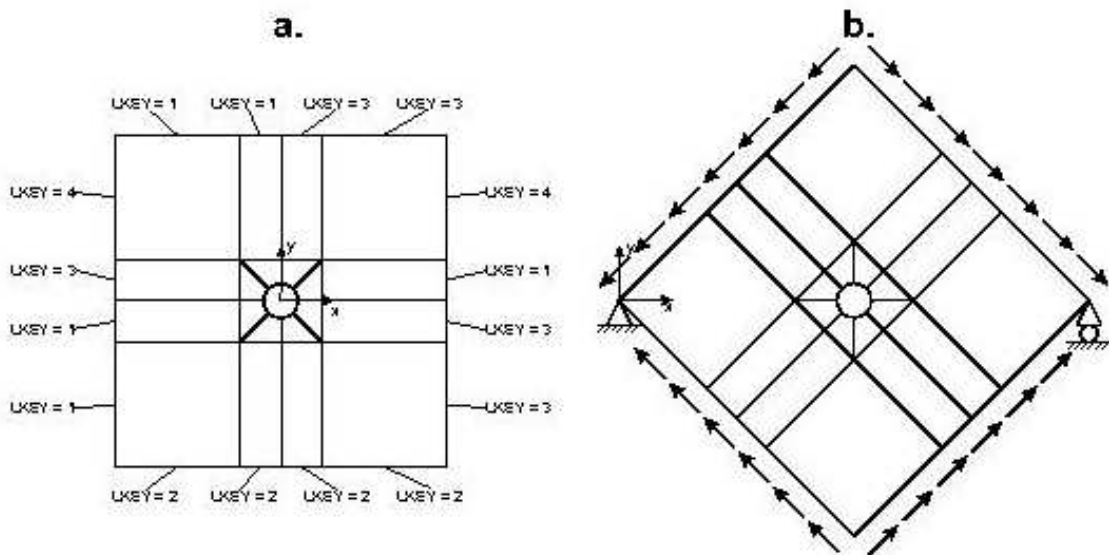

Fig.12.7. Definition of the LKEY parameter for the boundary lines of finite element model of the plate with central hole (a), definition of the boundary conditions by rotating the model (b).

Kinematic constraint, we create a local coordinate system, see Fig.12.7b.

PREPROCESSOR / MODELING / CREATE / KEYPOINT / IN ACTIVE CS /

$x = 0, y = 0, z = 0$ / OK

Workplane menu / Local Coordinate Systems / Create Local CS / By 3 Keypoints +

- selection of the point with coordinates $x = 40 \text{ mm}, y = 40 \text{ mm}$

- selection of the point with coordinates $x = 0, y = 0$

- selection of the point with coordinates $x = -40 \text{ mm}, y = 40 \text{ mm}$ /

OK

Display the model in coordinate system 11

Workplane menu / Change Display CS to / Specified Coord Sys / KCN = 11 / OK

(refresh the screen by the mouse roller)

PREPROCESSOR / LOADS / DEFINE LOADS / APPLY / STRUCTURAL / DIS-
PLACEMENT / ON NODES

- select the node with coordinates $x = 0, y = 0$ / OK / UX, UY / AP-
PLY

- select the node with coordinate $x = \sqrt{2} \cdot 80 \text{ mm}, y = 0$ / OK / UY /
OK

Read the load case as load step 2 (LS2)

PREPROCESSOR / LOADS / LOAD STEP OPTS / WRITE LS FILES / LSNUM = 2

Solution

SOLUTION / SOLVE / FROM LS FILES / 1 – 2

„SOLUTION IS DONE!”

Set the active and display coordinate system

Workplane menu / Change Active CS to / Global Cartesian

Workplane menu / Change Display CS to / Global Cartesian

(refresh the screen by the mouse roller)

Creation of load cases, read and multiplication

GENERAL POSTPROC / LOAD CASE / CREATE LOAD CASE / from Results file/ OK

LCNO = 1, LSTEP = 1, SBSTEP = Last / APPLY / OK

LCNO = 2, LSTEP = 2, SBSTEP = Last / OK

Read load cases

GENERAL POSTPROC / LOAD CASE / READ LOAD CASE 1 – normal load (f)

GENERAL POSTPROC / LOAD CASE / READ LOAD CASE 2 – tangential load (t)

Plotting and listing of the results

GENERAL POSTPROC / PLOT RESULTS / DEFORMED SHAPE / select DEF + UN-DEF EDGE / OK

PlotCtrls menu / Animate / Deformed Shape - animation

Nodal displacements, stresses and strains with color scale

GENERAL POSTPROC / PLOT RESULTS / CONTOUR PLOT / NODAL SOLU /

NODAL SOLUTION:	nodal displacements
DOF SOLUTION: UX, UY, USUM	displacements with color scale
STRESS:	normal and shear stresses, principal stresses, equivalent stresses
ELASTIC STRAIN:	strains and shear strains, principal strains, equivalent strains

Stresses, strains, element solutions with color scale

GENERAL POSTPROC / PLOT RESULTS / CONTOUR PLOT / ELEMENT SOLU /

ELEMENT SOLUTION:	element solutions
STRESS:	normal and shear, principal stresses, equivalent stresses
ELASTIC STRAIN:	strains and shear strains, principal strains, equivalent strains

Animation of displacements, stress and strains

PLOT CTRLS / ANIMATE / DEFORMED RESULTS ...

Select the result to be animated (DOF Solution / Stress, stb.), then define the number of frames and the time delay (in seconds).

Development of the normal stresses in y-direction in the 1. and 2. load step can be seen in the attached animation files (*pt_anim_12-01.avi*, *pt_anim_12-02.avi*).

Display the results in cylindrical coordinate system

GENERAL POSTPROC / OPTIONS FOR OUTP / RSYS Results coord system / Global cylindrical

The stress distributions are demonstrated in Fig.12.8 for the load case with uniaxial tension in x. The model is symmetric, therefore we present only the one half of it.

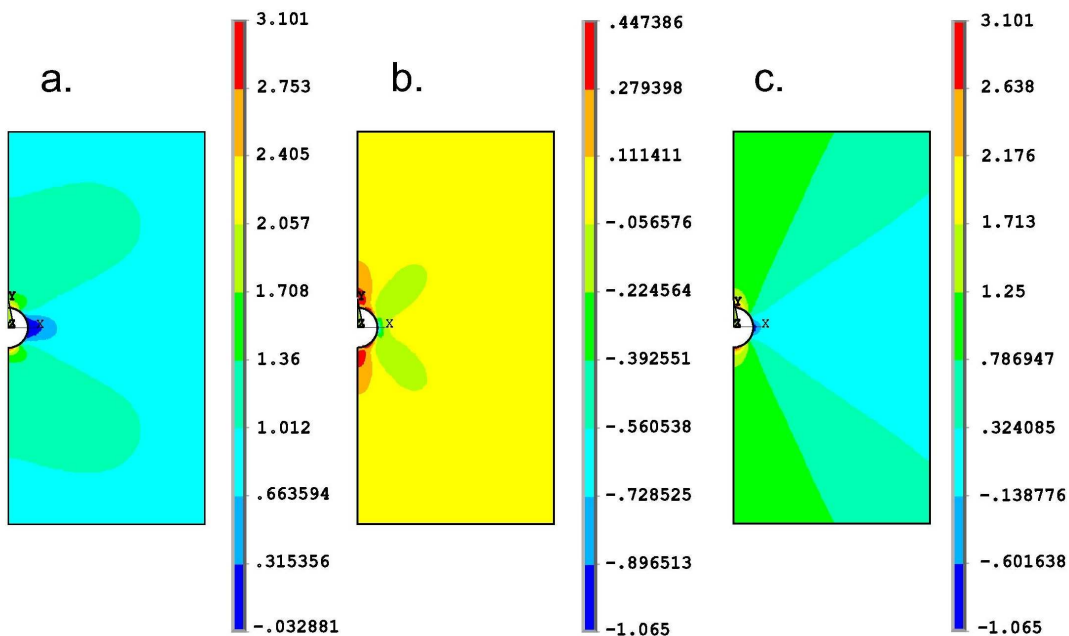

Fig.12.8. Stresses in the finite element model of the plate with hole in [MPa], σ_x (a) and σ_y (b) in the x-y coordinate system and σ_θ (c) in cylindrical coordinate system.

Displacements, stresses, strains along a predefined path

GENERAL POSTPROC / PATH OPERATIONS / DEFINE PATH / BY NODES

- selection of the starting and ending nodes of the vertical symmetry axis / OK /
- Name: ST90

GENERAL POSTPROC / PATH OPERATIONS / MAP ONTO PATH

- STRESS / X-DIRECTION, SX - selection of the normal stress in x

GENERAL POSTPROC / PATH OPERATIONS / PLOT PATH

- display the path by white line

GENERAL POSTPROC / PATH OPERATIONS / PLOT PATH ITEM / ON GRAPH
 - display the distribution

Changing the setup of diagram

PlotCtrls menu / Style / Graphs / Modify Axes

(The other stress components can be plotted in a same way)

Similarly to Figs.12.2 and 12.3 we show the stresses calculated by the finite element method. The results are shown in Figs.12.9 and 12.10a.

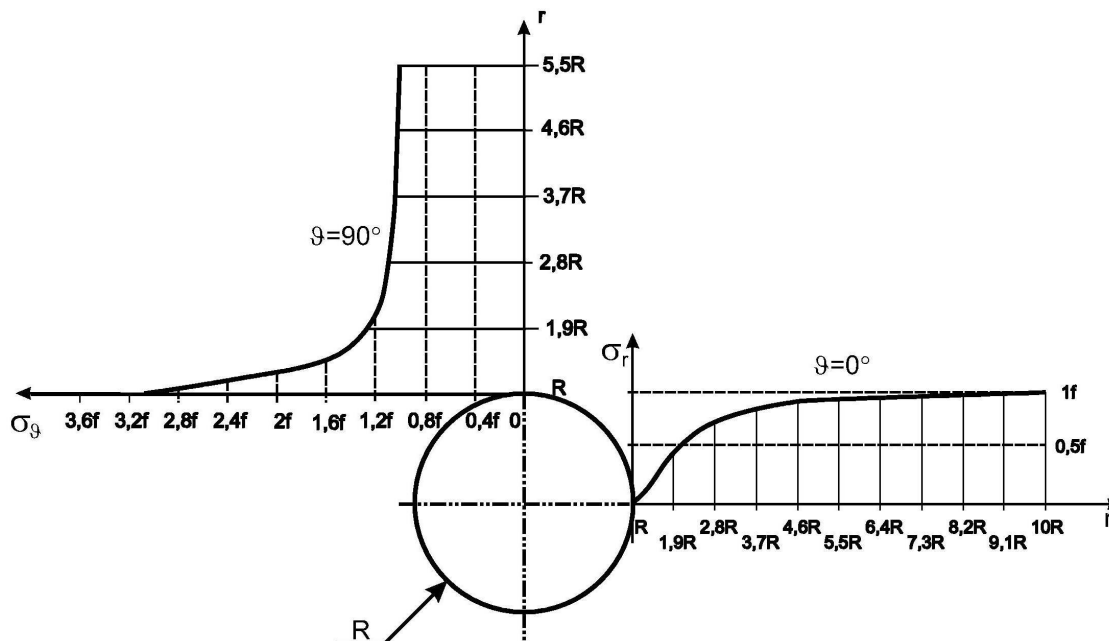

Fig.12.9. Tangential stresses in the plate for $\vartheta = 90^\circ$ and radial stresses for $\vartheta = 0^\circ$ obtained by the finite element solution.

The results for load case 2 can be processed by repeating the commands above. The results can also be listed. As an example let us see how to list the stresses along the central hole if the plate is subjected to “t” tangential load only.

Read the load case

GENERAL POSTPROC / LOAD CASE / READ LOAD CASE 2 – tangential load (t)

Select menu / Entities / Lines / By Numpick / From Full / OK /

- select the arcs of the hole / OK

Select menu / Entities / Nodes / Attached to / Lines, all / Reselect / OK /

- the nodes attached to the arcs are automatically selected

Display the results in cylindrical coordinate system

GENERAL POSTPROC / OPTIONS FOR OUTP / RSYS Results coord system / Global cylindrical

Listing the results

List menu / Results / Nodal solution / DOF solution / selection of the component
 / Stress / selection of the stress component,
 $SX = \sigma_r$, $SY = \sigma_\theta$, $SXY = \tau_{r\theta}$
 / Elastic strain / selection of the strain component
 / Element solution – element solutions
 / Reaction solution – listing the reactions

The distribution of the tangential stress, σ_θ along the boundary of the hole of is shown by Fig.12.10b.

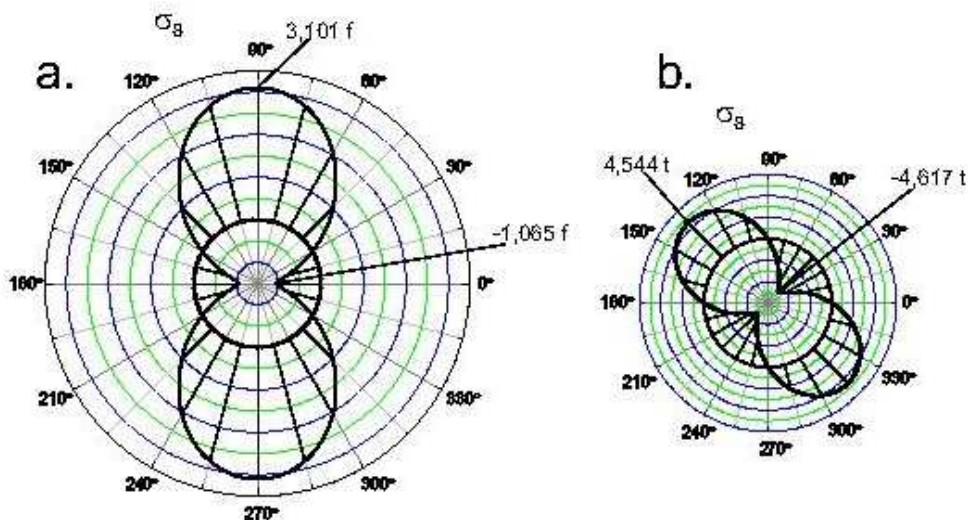

Fig.12.10. Tangential stresses along the hole of the plate with central hole under uniaxial tension in x (a) and tangential load (b) in accordance with the finite element solution.

Identification of the results by the mouse

GENERAL POSTPROC / QUERY RESULTS / SUBGRID SOLU – selection of the component

In a separated window

GENERAL POSTPROC / RESULTS VIEWER – selection of the component

12.3 Comparison of the results by analytical and finite element solutions

The stress distributions obtained from the two different solutions agree very well. Considering the finite element results in Fig.12.2 and the analytical results in Fig.12.9, respectively, there are only small differences in the stress distributions. The radial stress changes its sign if $r = \sqrt{1,5}R$ in accordance with the analytical solution (see Fig.12.2). On the contrary, there is no change in the sign according to the finite element solution (see Fig.12.9), which can be explained by the fact that the resolution of the finite element mesh is not fine enough in the corresponding part. The stress distributions along the circumference of the hole are presented in Figs.12.3 and 12.9 obtained from analysis and finite element calculation, respectively. The analytical and finite element solutions provide the same intersection points, where the stresses are equal to zero. Considering the maximum and minimum values of the stresses there are some differences, but these are not significant discrepancies.

12.4 Bibliography

- [2] Gábor Vörös, *Lectures and practices of the subject Applied mechanics, manuscript*, Budapest University of Technology and Economics, Faculty of Mechanical Engineering, Department of Applied Mechanics, 1978, I. semester, Budapest (in Hungarian).
- [2] L.P Kollár, G.S. Springer, *Mechanics of composite structures*, Cambridge University Press 2003, Cambridge, New York, Melbourne, Madrid, Cape Town, Singapore Sao Pãolo.
- [2] György Kozmann, *Strength of materials of beams with varying cross section*, Engineering Training Institute, lecture series from 1953-54: 2707, 1954, manuscript (in Hungarian).
- [4] ANSYS 12 Documentation. <http://www.ansys.com/services/ss-documentation.asp>.